

This manual is to be left
with the pump station or
the homeowner



Dual V4/V6

For Ground Water Applications

Installation Instructions

Ground Water Pump Station



Dual V4/V6

 0330 9000 999

 info@ppspumps.com

 www.ppspumps.com

Packaged Pumps Systems Ltd.

Unit 11, Haslemere Industrial Estate, Pig Lane, Bishop's Stortford, CM23 3HG

Legal information/Copyright

All rights reserved. Contents provided herein must neither be distributed, copied, reproduced, edited or processed for any other purpose, nor otherwise transmitted, published or made available to a third party without express written consent from Packaged Pumps Systems Ltd.

Subject to technical modification without prior notice.

Contents

1.0	Dual V4/V6 Overview.....	4
2.0	Parts Included.....	4
2.1	Optional Extras.....	4
3.0	Chamber Overview.....	5
4.0	Spare Parts.....	6
5.0	Technical Information.....	7
6.0	Pump Chamber Depth Limits.....	8
7.0	Installation Guidelines.....	9
8.0	Pump Station Location.....	9
9.0	RC Box Dimensions.....	9
10.0	Installation of Chamber.....	10
	Section A - Construction of reinforced concrete box.....	10
	Section B1 - Connecting 110mm pipework.....	11
	Section B2 - Connecting perimeter channel to chamber.....	12
	Section B3 - Connecting perimeter channel via a 1.5"/40mm inlet pipe.....	13
	Section C - Connecting discharge and cable duct.....	14
	Section D1 - Backfill around chamber with concrete (RC Box).....	16
	Section D2 - Backfill around chamber with concrete (Ground).....	17
	Section D3 - Backfill around chamber with concrete (Reinforced cage).....	18
	Section E - Installing pumps and high level alarm in chamber.....	19
11.1	Wiring Diagram (inc. AlertMaxx2).....	22
11.2	Wiring Diagram (inc. AlertMaxx2 & Hi-PowerMaxx).....	23
12.0	Maintenance.....	24
13.0	Health and Safety.....	24
14.0	Warranty.....	24
15.0	Troubleshooting.....	25
16.0	Notes.....	26

Dual V4/V6

1.0 Dual V4/V6 Overview

The Dual V4/V6 is a packaged pump station designed to collect ground water via perimeter channel or modular drainage system. Typically, the Dual V4/V6 would be used to collect ground water from a basement up to 150m² and/or surface water from a light well up to 12m² to a maximum head of 7m and 9m respectively.

The pump station has been specifically designed for below ground applications. The chamber is manufactured from HDPE and when installed correctly, it is able to withstand hydrostatic forces encountered in high water tables.

The pump station is delivered as a complete package including, the chamber, internal pipework and two powerful V4/V6 pumps. It is designed to be installed by contractors with competent building, plumbing and electrical skills. The pumps operate by fixed arm floats, the duty pump is set at a standard height (210mm to base of float) and the backup pump is set at a high level (380mm to base of float). The high level alarm (where fitted) will operate if the duty pump fails leaving the backup pump to discharge water.

An AlertMaxx2 high level alarm is offered as a recommended extra to alert the property occupant when the water level in the chamber becomes too high. A Hi-PowerMaxx2 battery backup is recommended to power the pumps during power outage. Please see section 2.1 for more details about optional extras designed for the Dual V4/V6 pump station.

2.0 Parts Included

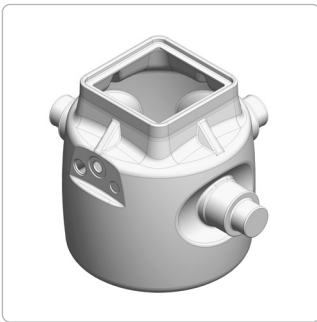

Chamber
902 x 655mm deep



1.25" Internal Pipework



2 x V4/V6 Pumps



2" Discharge Male Iron
& low pressure Male Iron
for temp. site installation.
2" Cable Duct Male Iron

2.1 Optional Extras



AlertMaxx2 High Level
Alarm (AMX2G)



Hi-PowerMaxx2 Battery
Backup (HiPMX2)

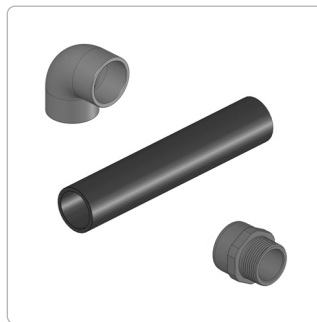

2" Discharge Pipework
and various fittings

3.0 Chamber Overview

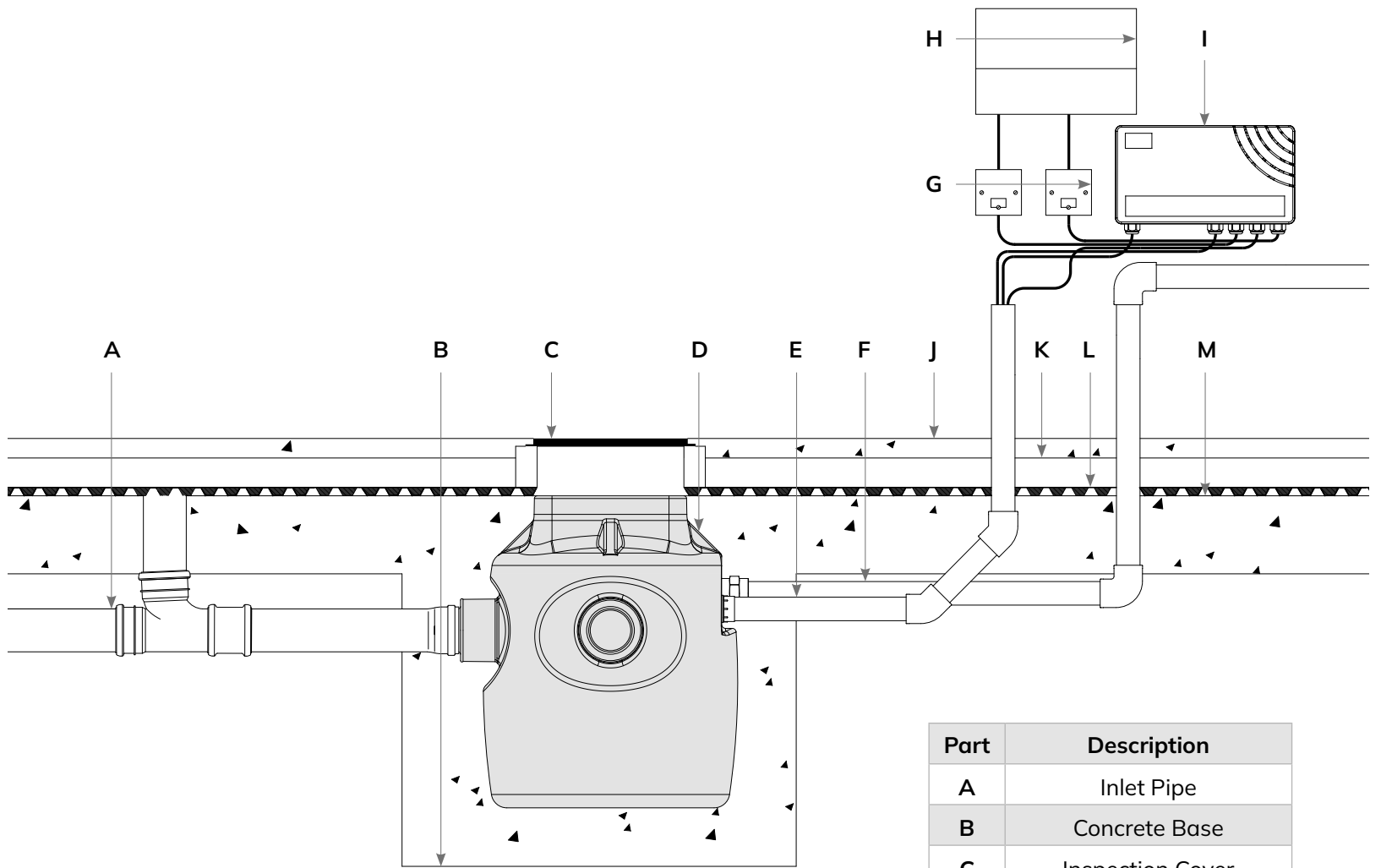

Part	Description
A	Inlet Pipe
B	Concrete Base
C	Inspection Cover
D	Pump Chamber
E	Cable Duct
F	Discharge Pipe
G	Non-switched Fused Spur
H	Distribution Board
I	High Level Alarm
J	Screed
K	Insulation
L	Membrane
M	Basement Slab

Dual V4/V6

4.0 Spare Parts

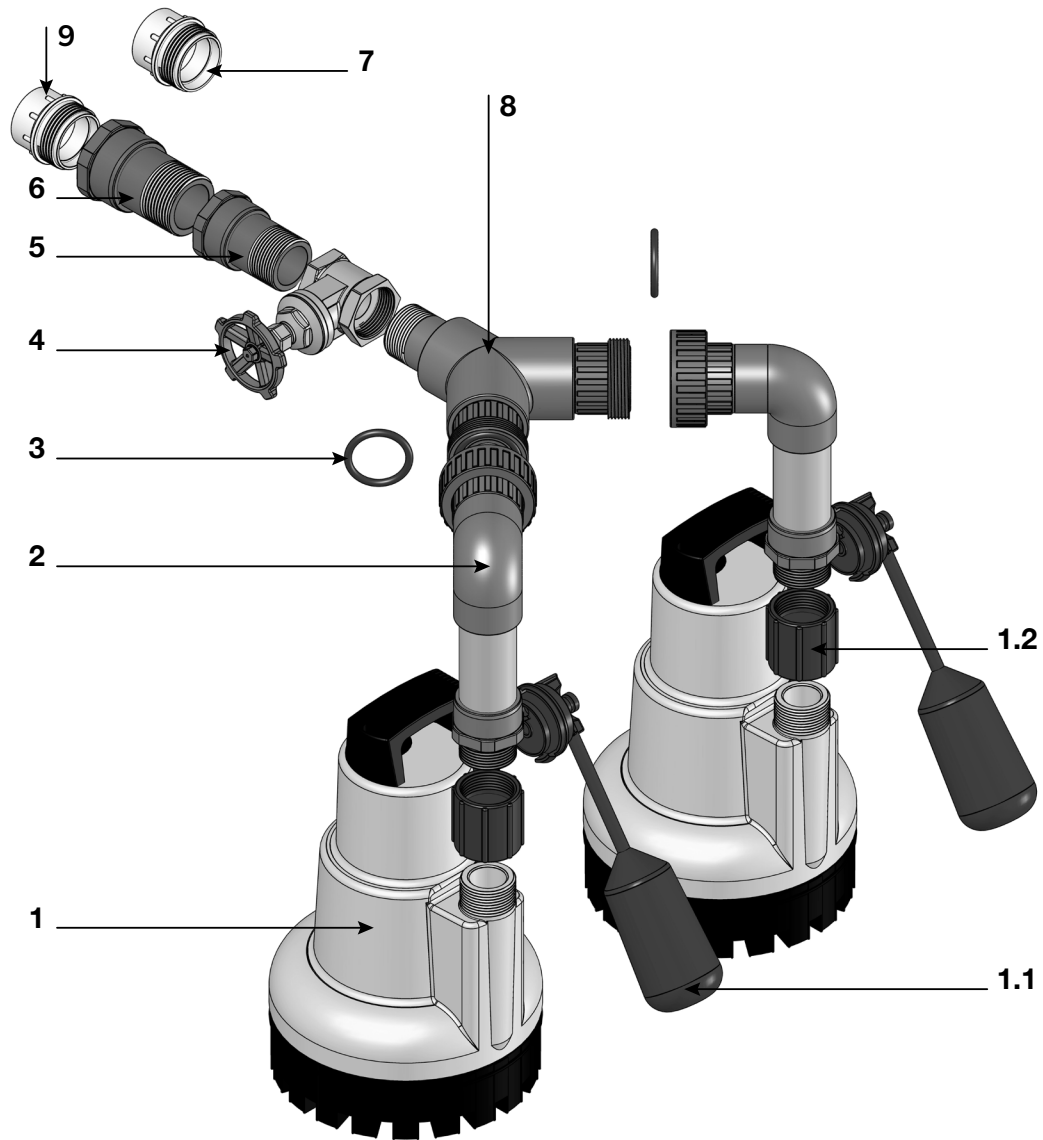

Part	Description	Part No.
1	V4/V6 Pump c/w 1.1 & 1.2	PU-001 / PU-002
1.1	Float Switch Assembly	PUS-FAS-01
1.2	Rubber Non-return Valve	V-A125-04
2	Discharge Arm inc. 'O' Ring	CS-DA-03
3	'O' Ring	PF-OR-01
4	1.25" Brass Gate Valve	V-A125-03
5	Connector Piece	CS-CA-04
6	Connector Adaptor	CS-CA-03
7	2" Non-pressure Male Iron	PF-A200-18
8	Y-piece c/w 2 'O' rings	CS-Y-01
9	2" male iron	PF-A200-08

5.0 Technical Information

Pump Specification				
Pump Type			V4	V6
Typical Duty (l/s)	Head (m)	3	3.25	3.75
		3.5	3.10	3.60
		4	3.00	3.50
		4.5	2.90	3.40
		5	2.75	3.30
		6	2.40	3.00
Power	P ₁ (kW)		0.75	1.05
	P ₂ (kW)		0.35	0.50
Current (a)			4.00	4.90
Power Phase			Single	Single
Non-switched Fuse Spur Rating (a)			13	13
RCBO Rating (a)			16	16
Cable Length (m)			10	10
Max. Temperature (°C)			50	50
Weight (kg)			7.17	7.40

Chamber Specification		
Chamber Material	High Density Polyethylene - ICO1314 grade	
Size (mm)	Chamber Diameter	660
	Overall Diameter	902 (across spigots)
	Depth	800
Volume (L)	Below Inlet	137
	Total	273
Inspection Cover	Not supplied	
Clear opening to chamber (mm)	310 x 310	
Fixed Inlets	3 x 110 / 160mm	
Cable Duct (mm)	50	
Vent	N/A	
Discharge Connection	2" / 50mm BSP Female - External to chamber	
Internal Pipework Manifold	1.25" / 32mm BSP Class C	

Dual V4/V6

6.0 Pump Chamber Depth Limits

If the inlet does not allow the pump chamber to be within depth limits, please contact Packaged Pumps Systems on 0330 9000 999 to discuss chamber options.

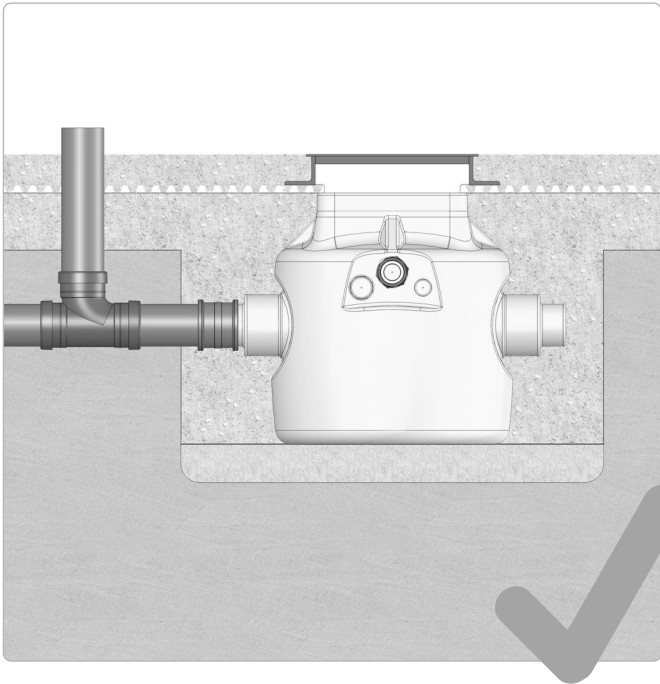

< 500mm

The pump chamber must be installed no more than 500mm below floor finishes.

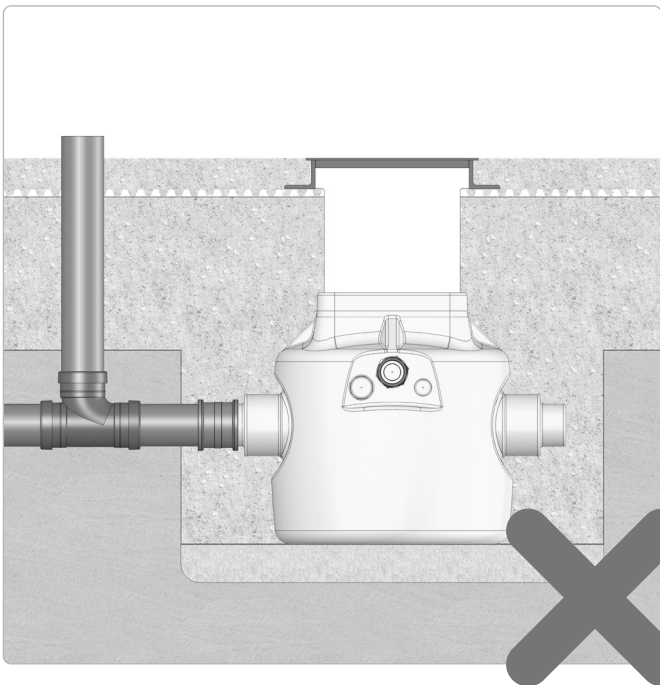

> 500mm

A pump chamber installed more than 500mm below floor finishes cannot be serviced safely in accordance with CDM regulations.

7.0 Installation Guidelines

The following instructions are for guidance only and it is the contractor's responsibility to ensure that the installation is in accordance with the prevailing ground conditions and good building practice, to eliminate any potential damage to the pump station either during or after installation.

Please read these instructions carefully prior to installing the chamber. If there is anything that is unclear, the Packaged Pumps Systems Technical department is available on 0330 9000 999.

8.0 Pump Station Location

This station requires routine maintenance, therefore it is important that careful consideration is taken to position the chamber in a location that allows permanent access to the chamber.

9.0 RC Box Dimensions

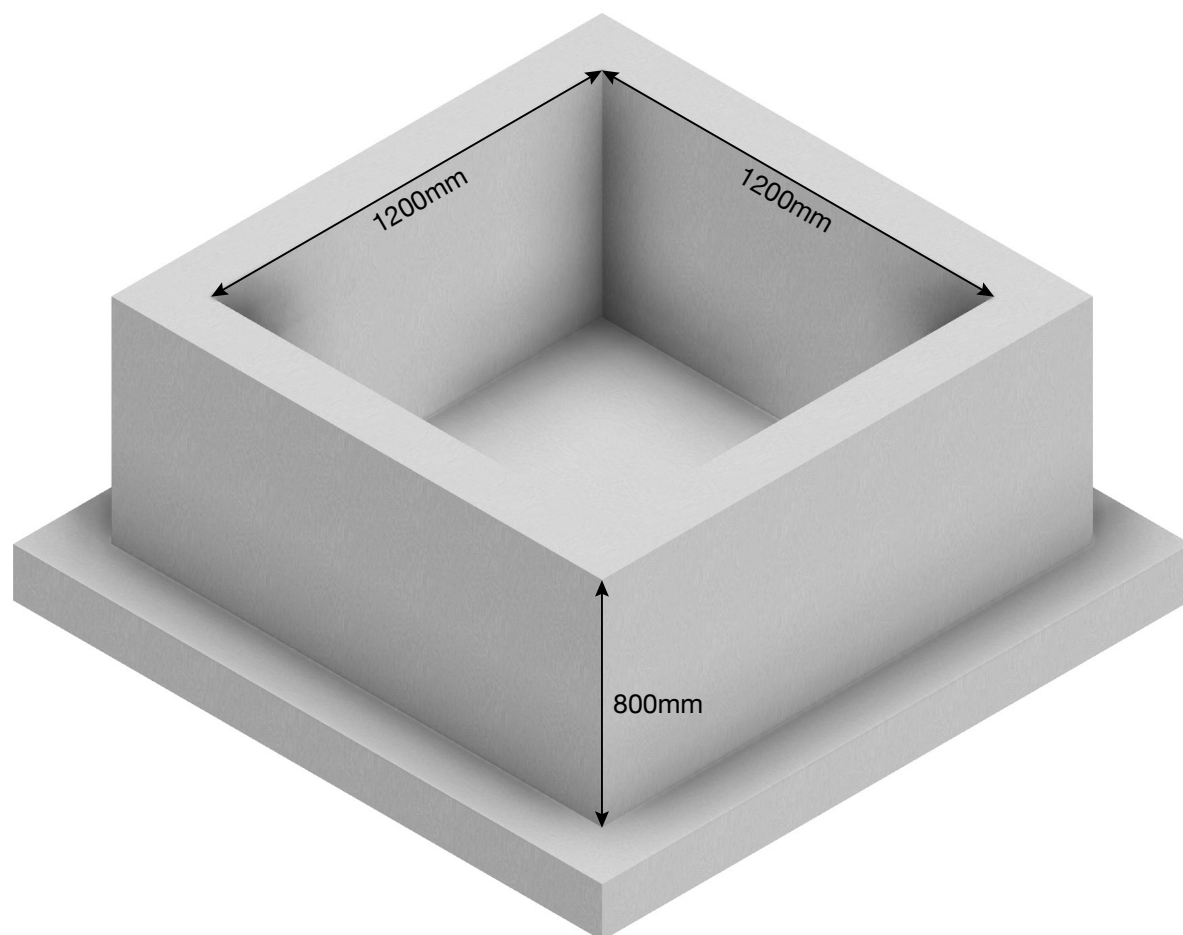

Dual V4/V6

10.0 Installation of Chamber - Section A

Construction of reinforced concrete box



1
Excavate hole for chamber. Refer to section 10.0 for RC box internal dimensions.

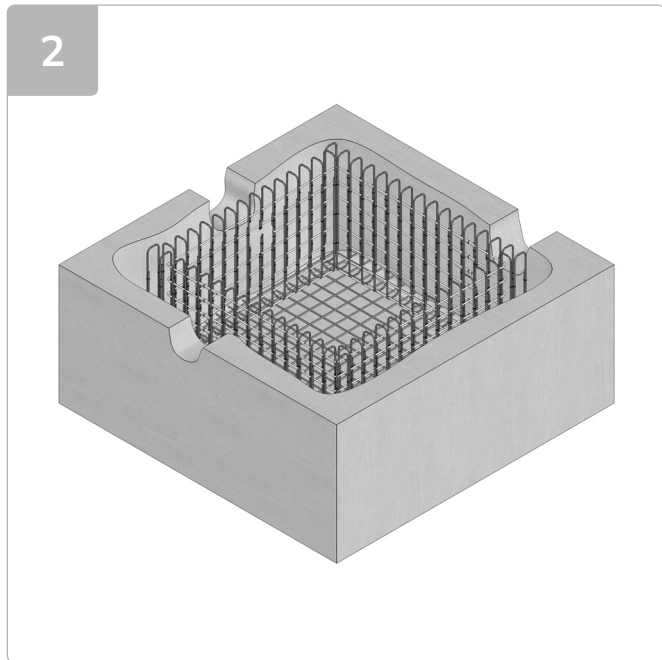

2
Install re-bar as per structural engineer's drawings.

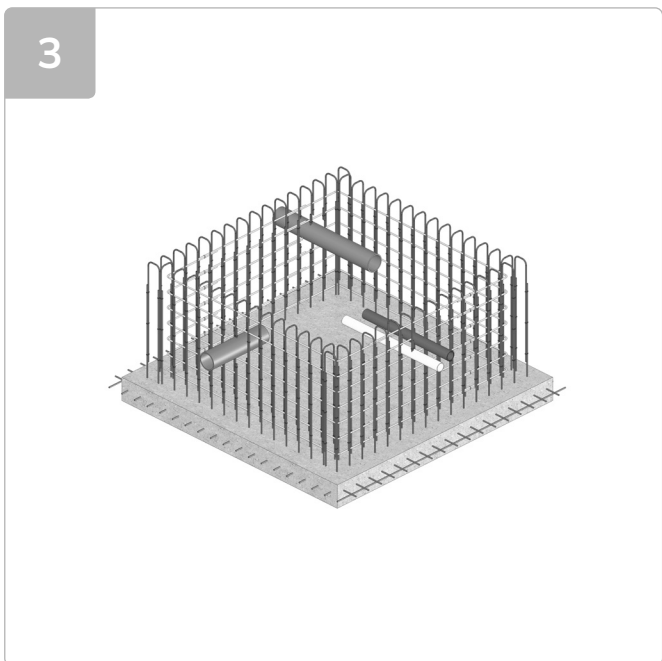

3
Lay inlet and discharge pipework. Allow pipework to protrude into RC box by a minimum of 100mm.

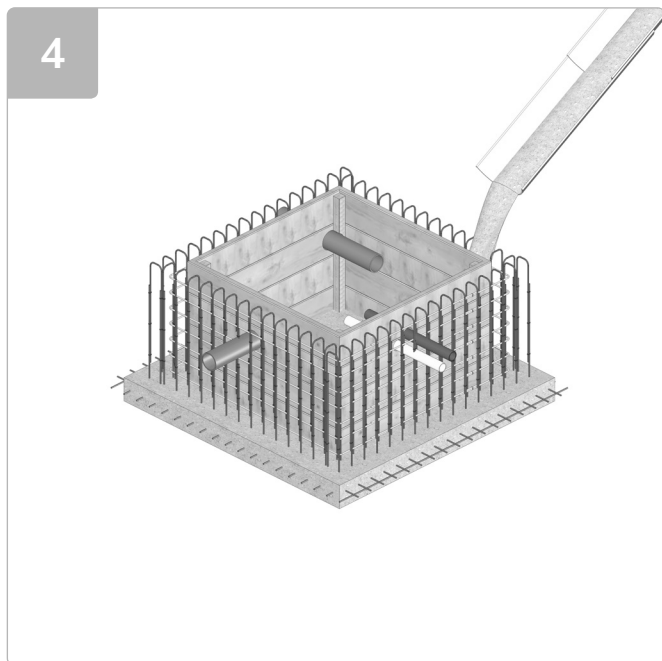

4
Pour concrete to form RC box as per structural engineer's drawings.

10.0 Installation of Chamber - Section B1

Connecting 110mm pipework

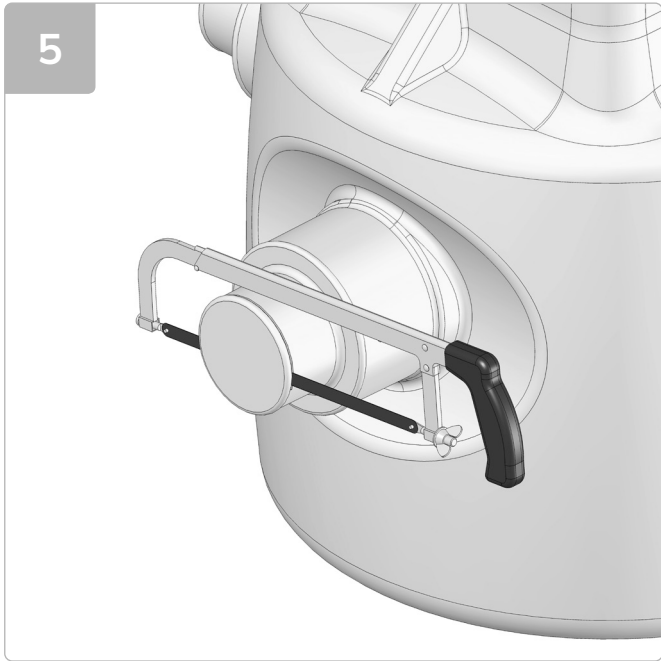

Saw off socket end/s, where inlet pipe/s are to be connected.

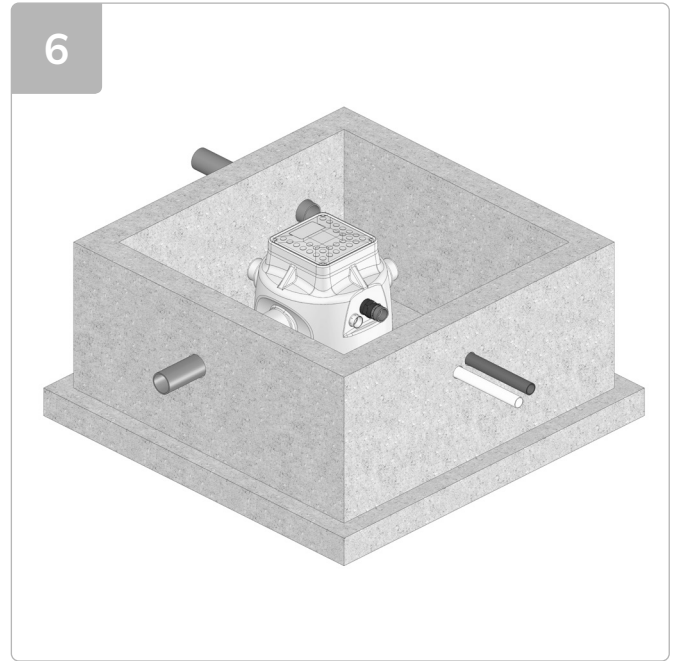

Position chamber in RC box.

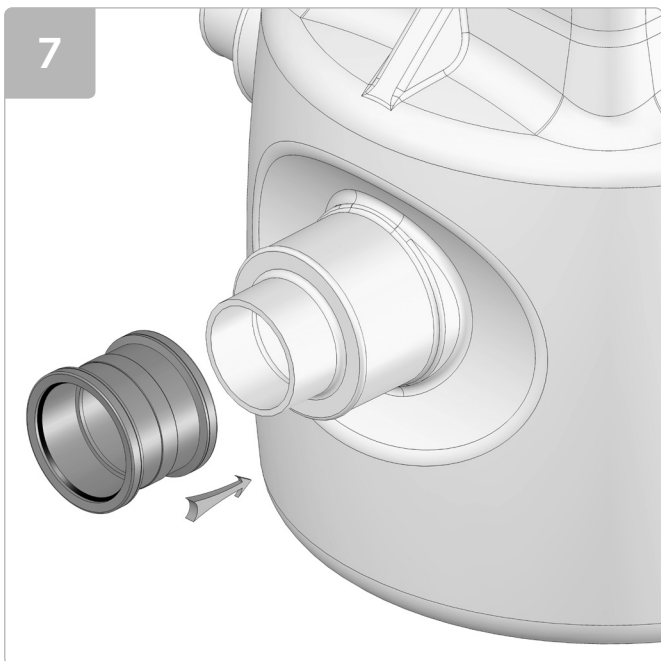

Fit push fit coupler.

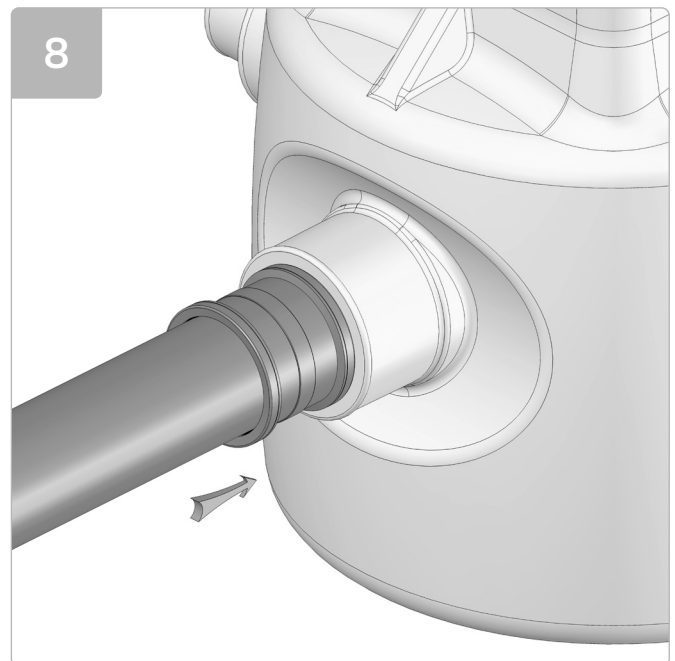

Connect inlet pipework to the required chamber spigot.

Dual V4/V6

10.0 Installation of Chamber - Section B2

Connecting perimeter channel to chamber

To be followed when installing perimeter channel directly into upper side of chamber.

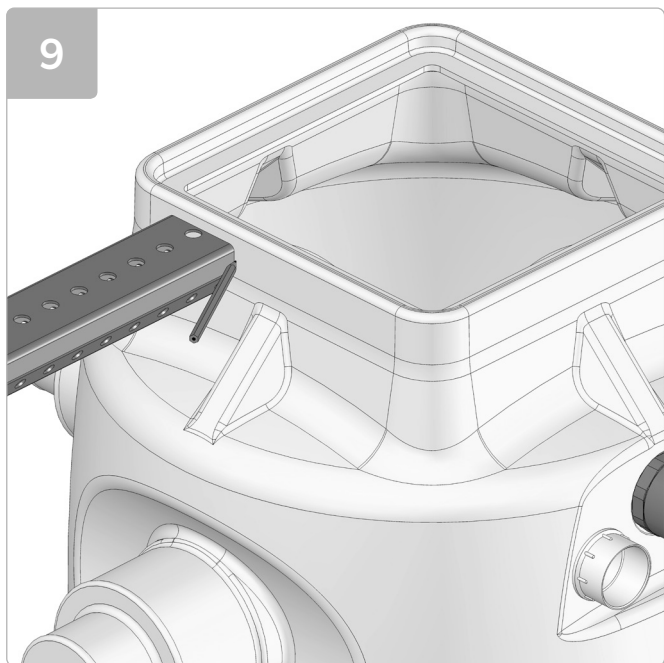

Mark perimeter channel position on side of chamber.

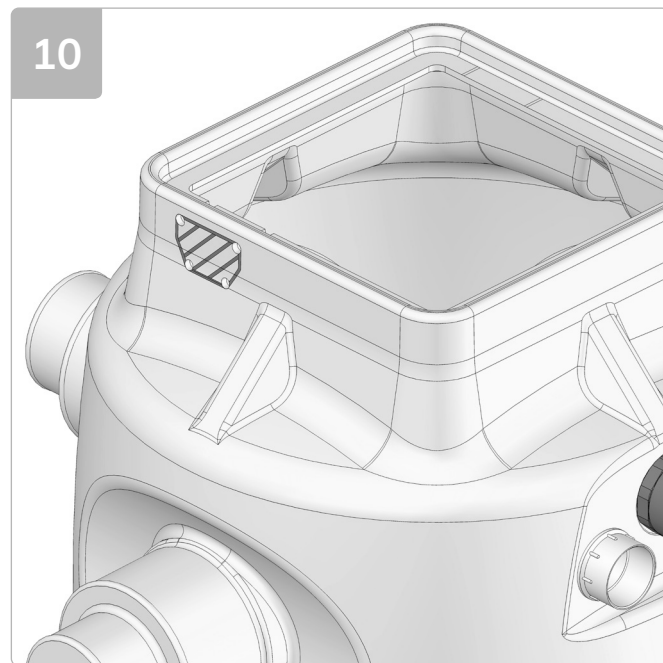

Drill holes in the corners inside the area marked in red.

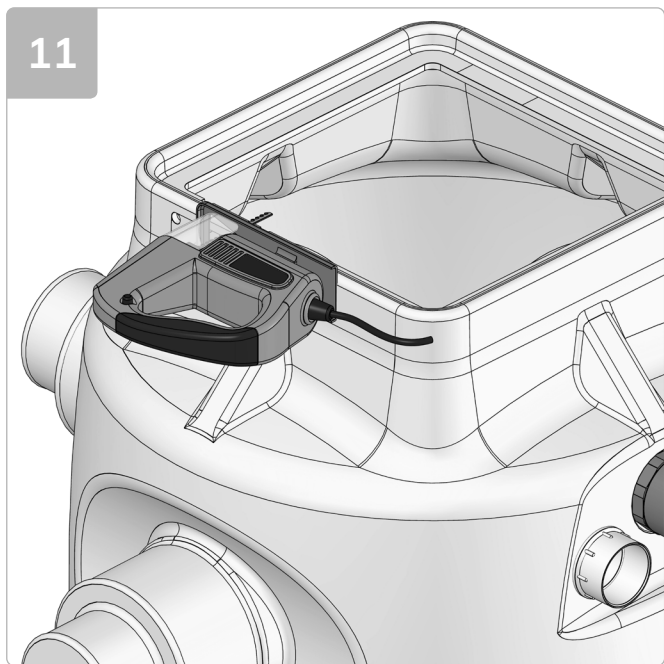

Cut around the marked line outlining the perimeter channel using a jigsaw.

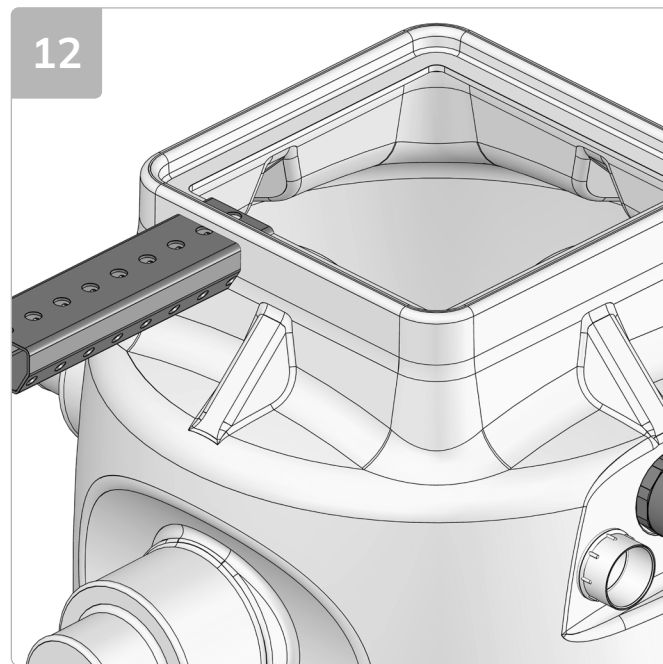

Insert the perimeter channel into the chamber allowing 35mm of overhang inside the chamber.

10.0 Installation of Chamber - Section B3

Connecting perimeter channel via a 1.5"/40mm inlet pipe

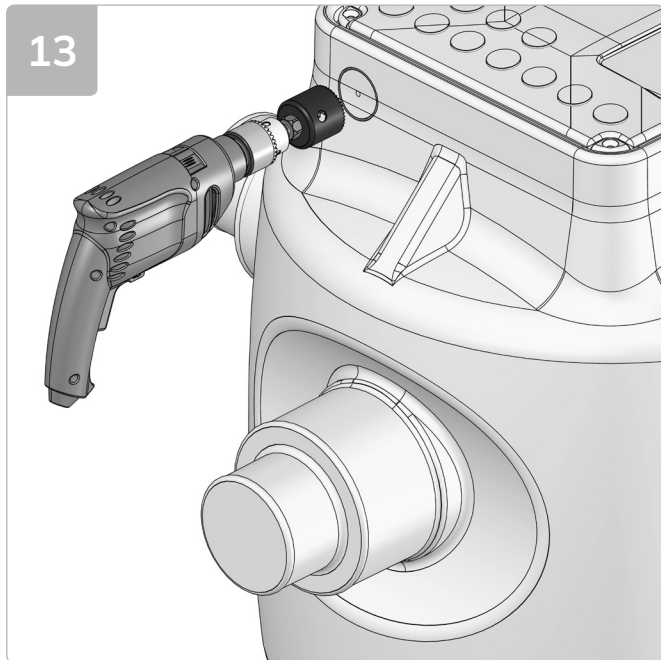

Mark position of the 40mm pipe on the side of the chamber and cut out the marked line using a 1.5"/40mm holesaw.

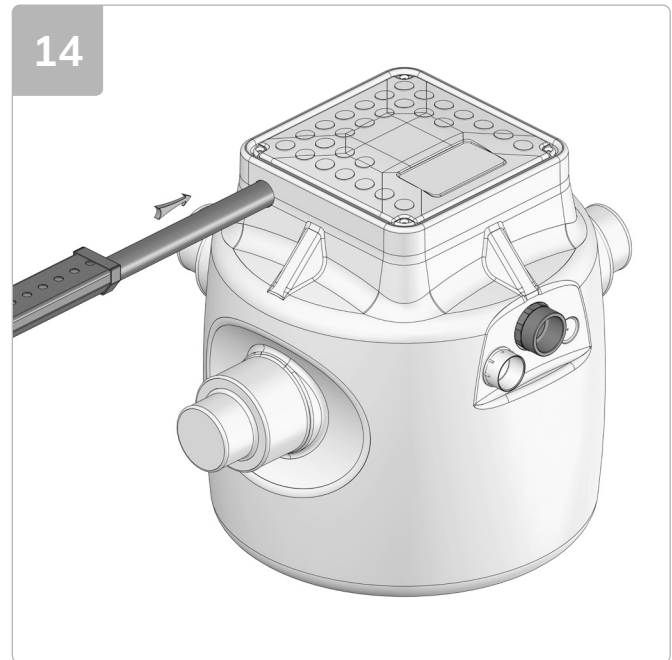

Cut 40mm pipe to length allowing an overhang of 35mm inside the chamber.

Dual V4/V6

10.0 Installation of Chamber - Section C

Connecting discharge and cable duct

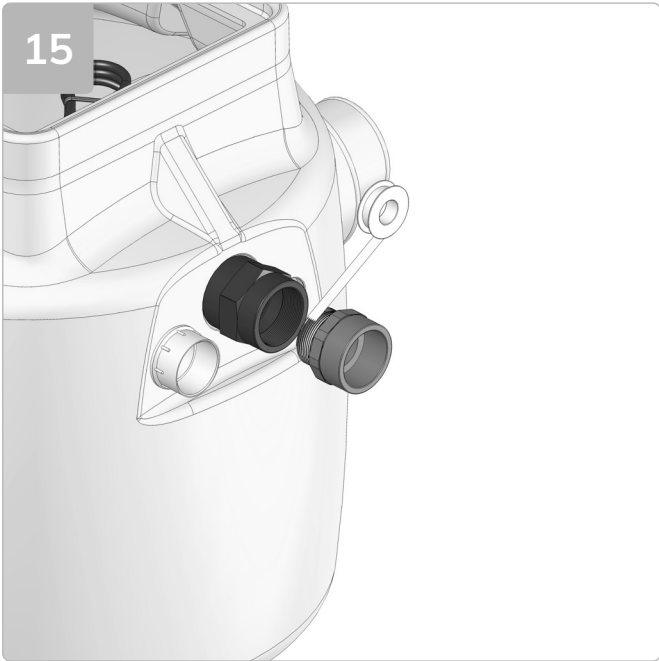

Wrap the thread on the high pressure male iron with PTFE tape.



Screw the high pressure male iron into the female iron.



Apply high pressure glue around the first 20mm of the external face of the discharge and cable duct pipe and internal side of their respective male iron.



Push discharge and cable duct pipe into their respective male iron, twisting the pipe as it is pushed into the male iron to remove any trapped air.

10.0 Installation of Chamber - Section C cont.

Connecting discharge and cable duct

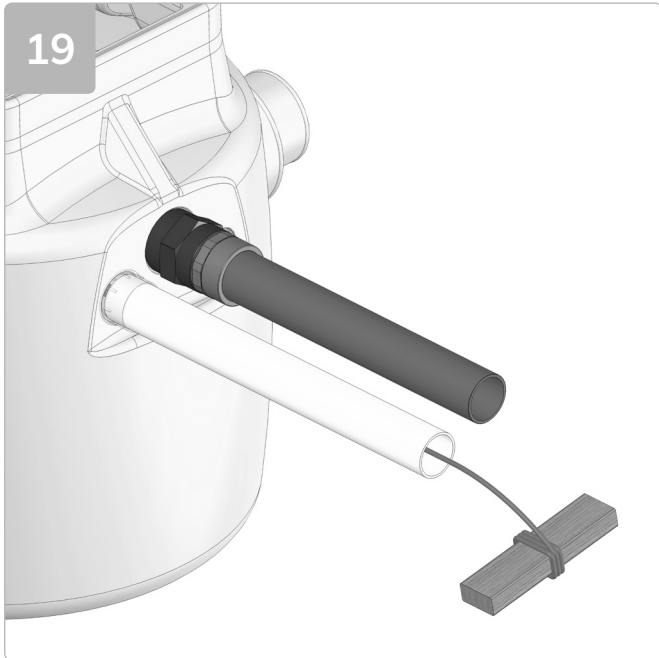

Ensure a draw cord is pulled through the cable duct as the cable duct is built.

Dual V4/V6

10.0 Installation of Chamber - Section D1

Backfill around chamber with concrete

To be followed when installing chamber in an RC box.

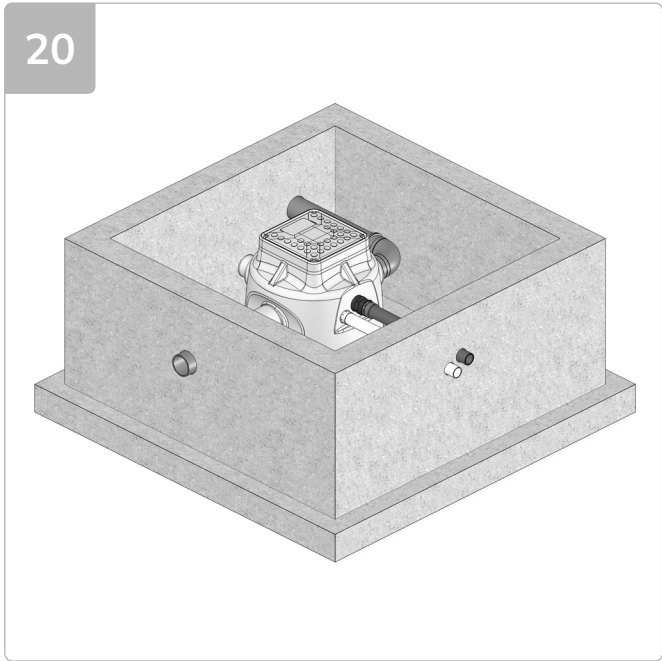

Check all pipes are connected to the chamber correctly.

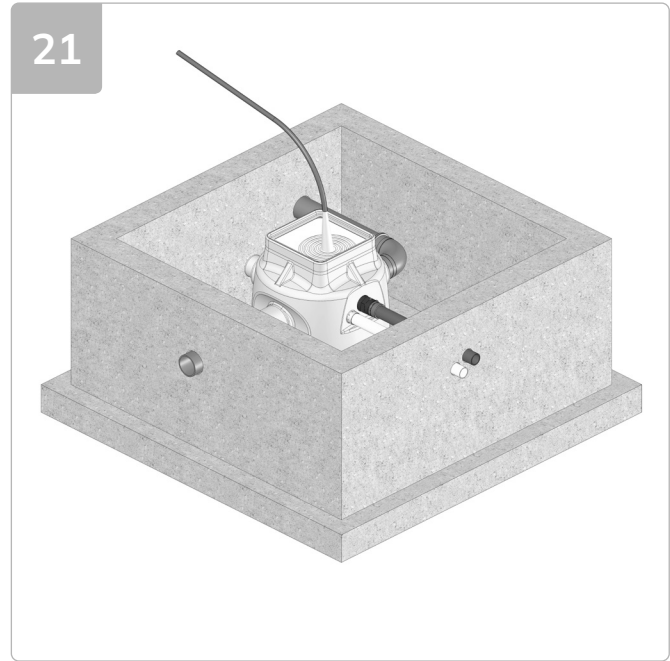

Completely fill chamber with water.

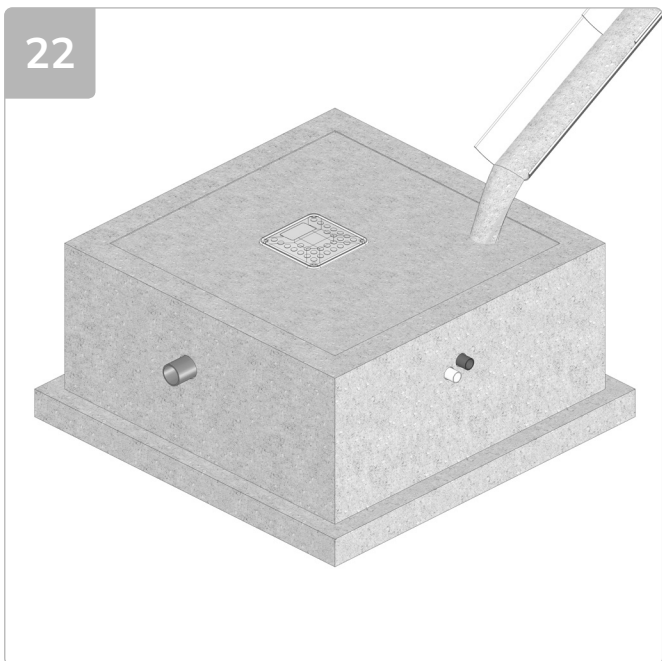

Fill void between RC box and chamber with concrete (min. C35 grade) or as per engineer's drawings.

10.0 Installation of Chamber - Section D2

Backfill around chamber with concrete

To be followed when installing chamber in the ground.

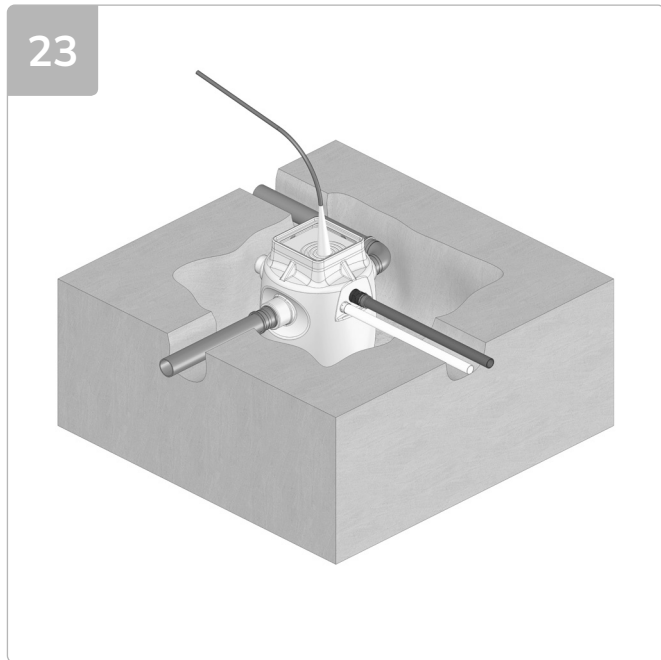

Completely fill chamber with water.

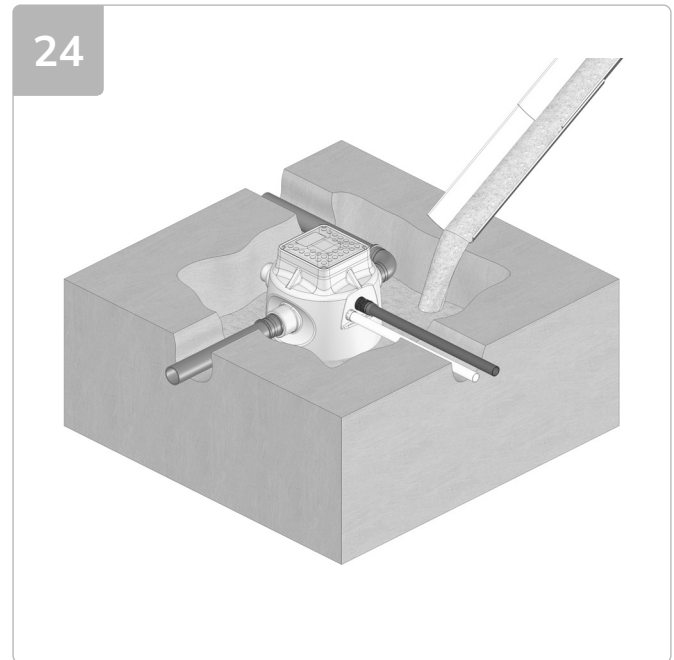

Fill void between soil and chamber with concrete (min. C35 grade) or as per engineer's drawings.



Allow concrete to cure.

Dual V4/V6

10.0 Installation of Chamber - Section D3

Backfill around chamber with concrete

To be followed when installing chamber in the ground with a reinforced cage.

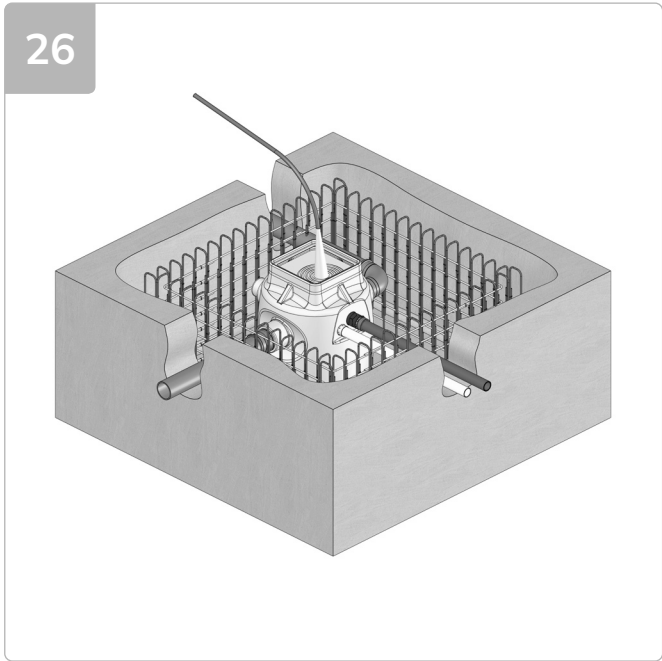

Completely fill chamber with water.

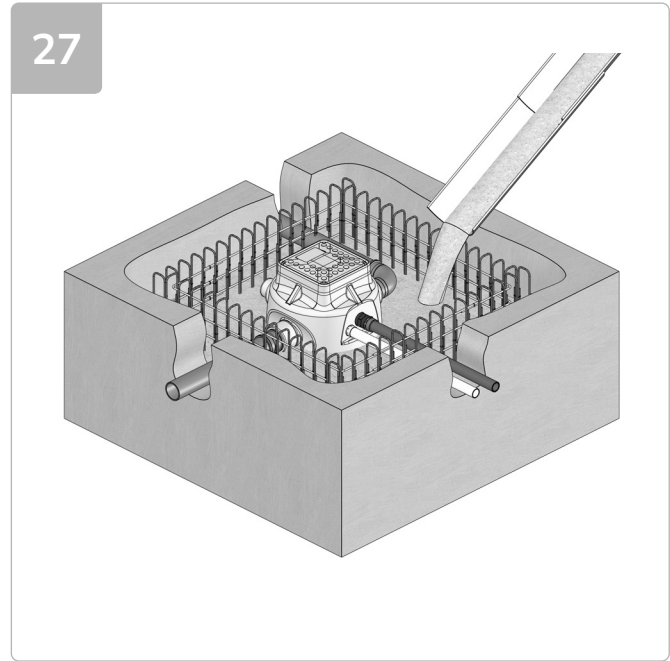

Fill void between soil and chamber with concrete (min. C35 grade) or as per engineer's drawings.



Allow concrete to cure.

10.0 Installation of Chamber - Section E

Installing pumps and high level alarm in chamber

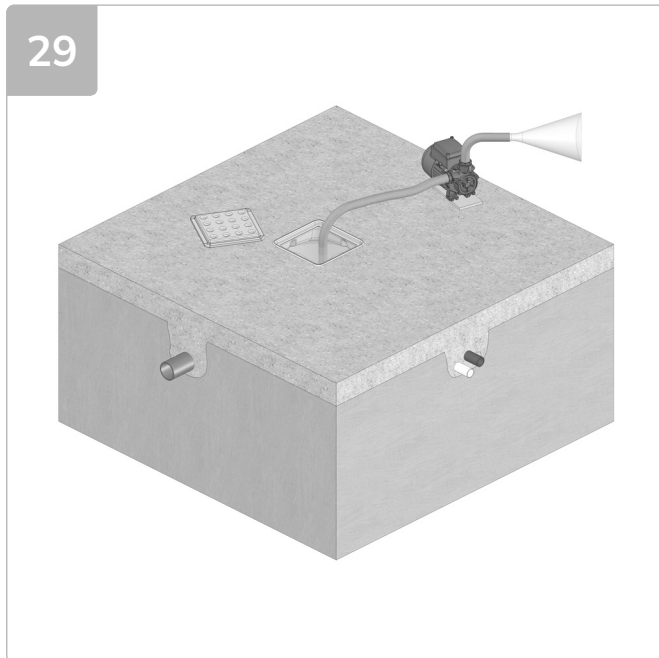

Pump out water from chamber.



Manually remove any debris from chamber and residual water using a wet vac.

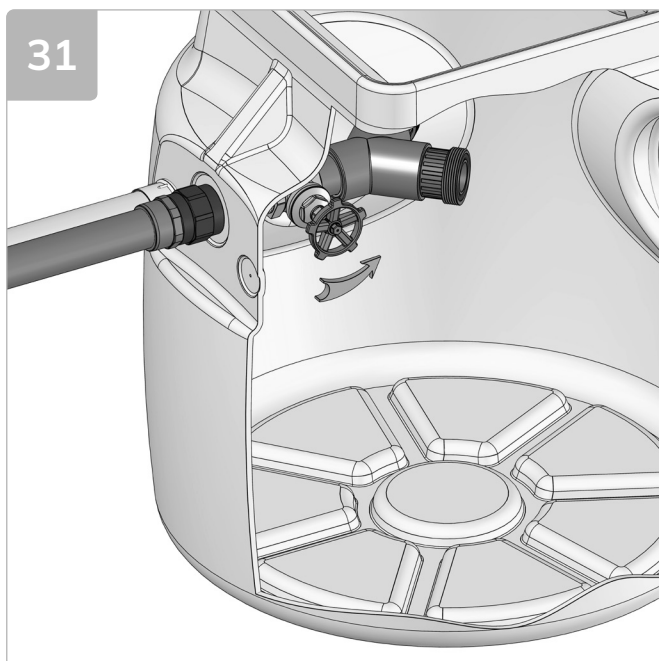

Remove discharge arms from 'Y' piece manifold and screw 'Y' piece on to gatevalve. Ensure gatevalve is fully open.



Wrap PTFE tape around thread located on male irons at the bottom of the discharge arms and screw discharge arms on to pumps.

Dual V4/V6

10.0 Installation of Chamber - Section E cont.

Installing pumps and high level alarm in chamber

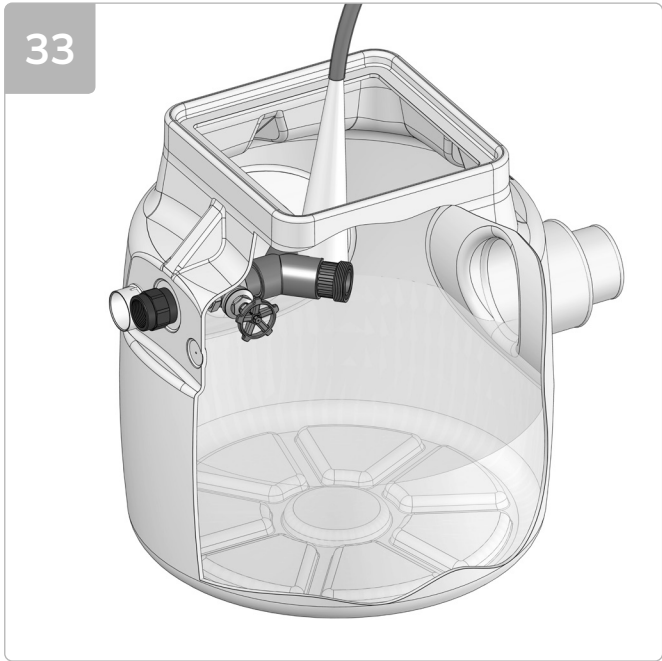

Fill chamber half full with water.



Lower pumps in to chamber. Ensure 'O' rings are correctly seated in unions and screw discharge arms to 'Y' piece manifold.



When installing an AlertMaxx2 high level alarm, refer to the high level alarm installation instructions.

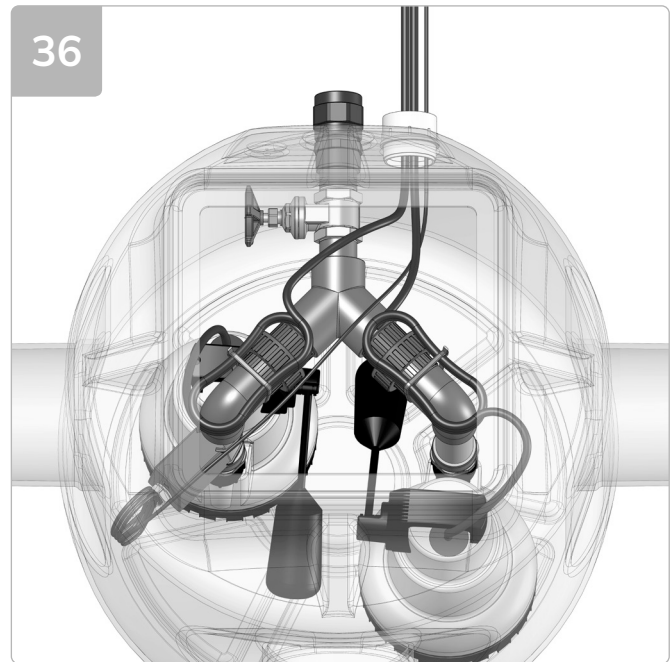

Pull pump and high level alarm cables through cable duct.

10.0 Installation of Chamber - Section E cont.

Installing pumps and high level alarm in chamber

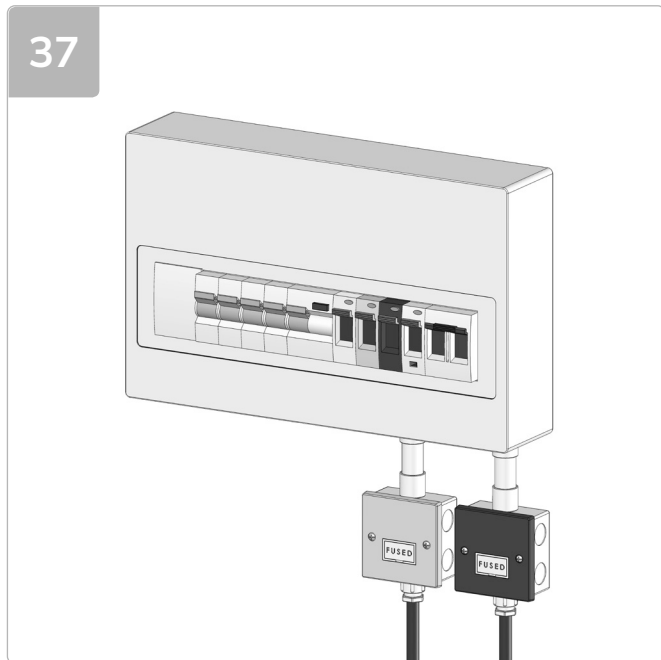

Isolate main supply and connect each pump to a separate non-switched fused spur. When installing an AlertMaxx2, follow the wiring diagram on page 22.



Turn mains supply on and lift each pumps float arm to test water is discharging correctly.



To test float switch, refer to the high level alarm installation instructions.



Re-fit temporary site cover to protect the pump station.

Dual V4/V6

11.1 Wiring Diagram (inc. AlertMaxx2)

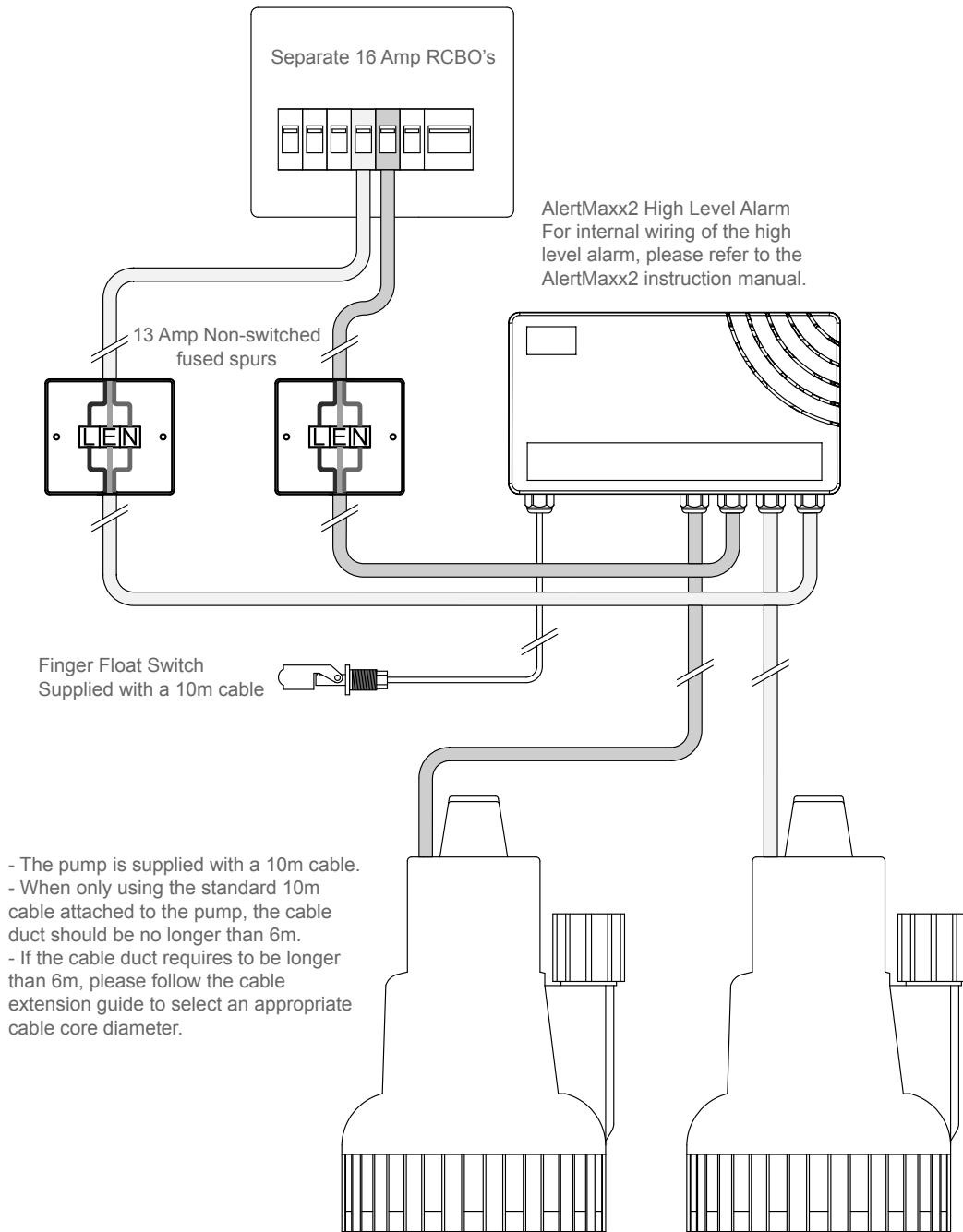

The electrical installation must comply with the requirements of BS 7671:2018 'Requirements for Electrical Installations' incorporating the latest amendment.

11.2 Wiring Diagram (inc. AlertMaxx2 & Hi-PowerMaxx)

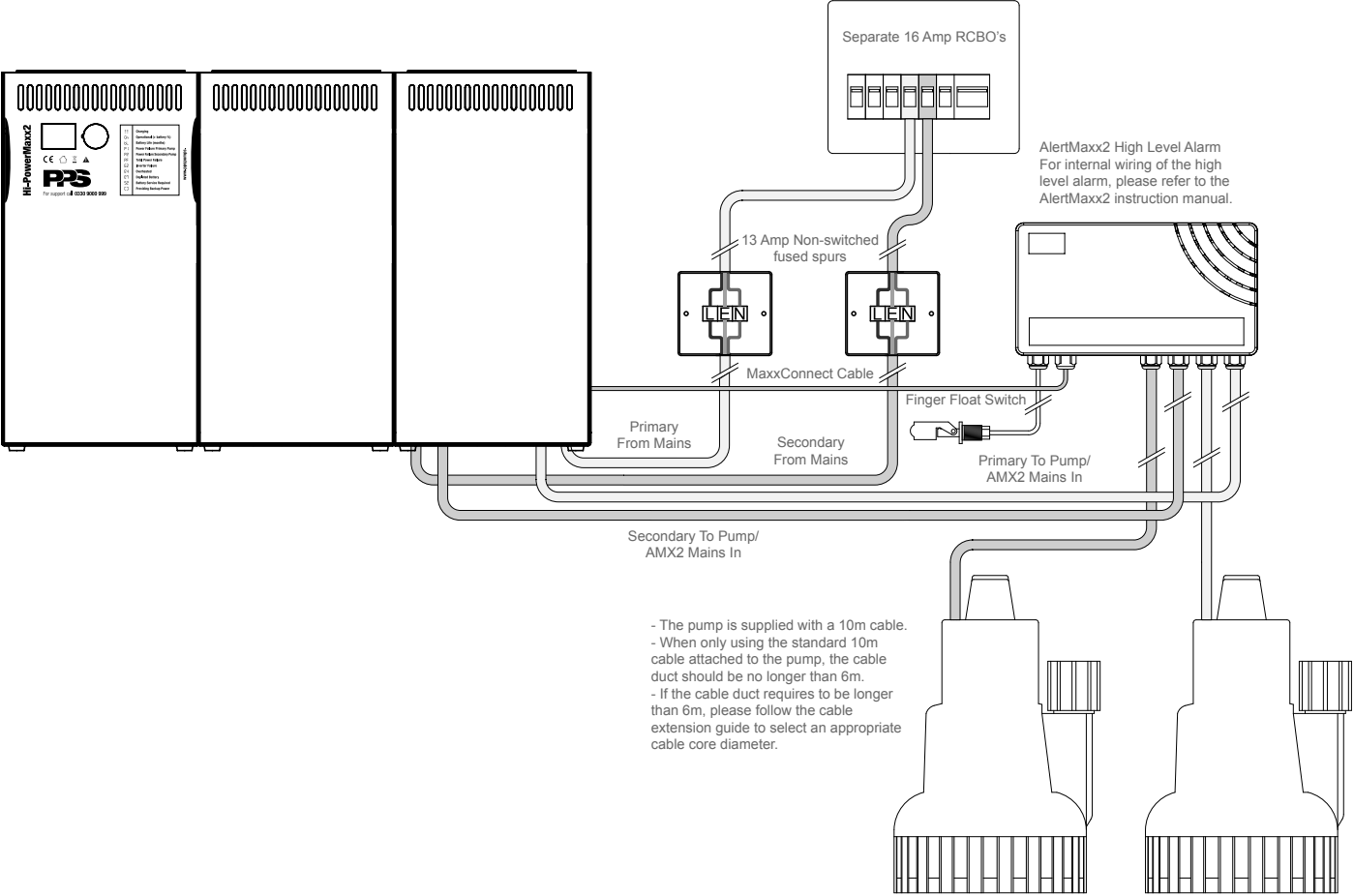

- The pump is supplied with a 10m cable.
- When only using the standard 10m cable attached to the pump, the cable duct should be no longer than 6m.
- If the cable duct requires to be longer than 6m, please follow the cable extension guide to select an appropriate cable core diameter.

The electrical installation must comply with the requirements of BS 7671:2018 'Requirements for Electrical Installations' incorporating the latest amendment

Dual V4/V6

12.0 Maintenance

In accordance with BS12056-4 and BS8102:2022, sump pumps must be maintained. We recommend a qualified engineer examines and services equipment every year. Pumps running frequently due to higher water table, water drainage, or weather conditions should be examined more frequently, we recommend every 6 months. Sump pumps, being mechanical devices, may fail if not maintained, which could lead to a flooded basement and costly repairs.

Regular servicing of sump pumps will increase efficiency and extend the life of the pump. All our pump systems can be maintained by our Service department (www.ppsumps.com or 0330 9000 999) or by the installing contractor.

13.0 Health and Safety

In order to minimise the risk of ill health or accidents when installing and/or servicing pump chambers, workers must be fully trained, competent and follow the health and safety guidelines below:

- Do not work without a risk assessment being in place.
- Work in accordance with the control measures identified in the risk assessment.
- All personnel must be vaccinated against diseases to which they may be exposed to, i.e. Tetanus, Polio, Hepatitis A&B, etc.
- At the time of writing, due to there being no vaccine against leptospirosis/weil's disease, where rats may be present, ensure appropriate personal protective equipment (skin protection) is worn and ensure any cuts or abrasions are fully covered.
- There should be no eating or drinking during works and only afterwards following a change of clothing and washing.
- Ensure electrical power to the pump is turned off/isolated before carrying out installation or maintenance.
- A suitable first aid kit must be close to hand.

14.0 Warranty

The Dual V4/V6 pump station is offered with an 18 month component warranty. This warranty only covers any defects in workmanship, construction or material. This warranty does not cover, defects caused by incorrect installation, installer error, abnormal working conditions, misuse or neglect.

Pump stations that **have not** been commissioned **have** a 18 month component warranty from date of delivery. Pump stations that have been commissioned by Packaged Pumps Systems have an 18 month component warranty from date of commissioning.

Any defects or malfunctions should be reported to Packaged Pumps Systems immediately to avoid any damage to other components. All broken components must be sent to us at the customer's cost.

To make a pump or accessory warranty claim, please visit: www.ppsumps.com/help-support/log-a-warranty-claim

We exclude all liability for any consequential or other damage or losses which may occur. We will not be liable if the pumping system fails due to it having been incorrectly specified (e.g. where a pump is subjected to flow rates higher than recommended or where a pump is used to discharge inappropriate fluids/solids, such as building debris or materials).

15.0 Troubleshooting

Please ensure the installation process has been completed thoroughly and all steps have been followed correctly.

Use the table below to assist with troubleshooting and if problems still occur, please contact the Packaged Pumps Systems Technical department on **0330 9000 999** from 9:00am - 5:00pm or email **info@ppspumps.com**

Fault	Cause
Water leaking from discharge arms.	'O' rings missing or not installed correctly in unions. PTFE tape not applied to male irons on discharge arms when attached to pumps.
Pump isn't running.	Pump hasn't got power - check wiring with reference to section 12.0 wiring diagram. Float arm isn't lifting - check float arm is free moving and not catching on chamber or other pump - make sure pumps are positioned as diagram 38. Float arm not turning on pump - can you hear a click when lifted slowly? If not, call us on 0330 9000 999.
Pump running but not pumping water or discharging very slow (more than 40 seconds to empty chamber).	Gate valve isn't open or partially closed - turn valve anticlockwise to open. Pump is air locked - make sure there is a level of water to the top of the pumps, remove pump from union and lower back into water, lift float arm to activate pump before reconnecting to discharge arm. Discharge pipe is blocked - a drainage company is required. Pump impellor is jammed - turn off power and isolate pump, remove pump from chamber, unscrew pump base using Torx screwdriver and free impellor. WARNING! - Insure mains power and pump is isolated before taking pump apart and seek advice from a qualified electrician.
Pump is tripping.	Pump is wired incorrectly or not on a separate supply - refer to section 12.0 wiring diagram. Pump impellor is jammed - turn off power and isolate pump, remove pump from chamber, unscrew pump base using Torx screwdriver and free impellor. WARNING! - Insure mains power and pump is isolated before taking pump apart and seek advice from a qualified electrician.
High Level Alarm not functioning.	Refer to the high level alarm installation & operating instructions.

Dual V4/V6

16.0 Notes

 0330 9000 999

 info@ppspumps.com

 www.ppspumps.com

Packaged Pumps Systems Ltd.

Unit 11, Haslemere Industrial Estate, Pig Lane, Bishop's Stortford, CM23 3HG