

REGO1

OVERVIEW & FEATURES

- The Rego1 is a new generation, intelligent pump station control panel. The replacement of analogue circuitry with digital technology enables various advantages:
- Improved time and efficiency of installation.
- Enhanced float logic with digital float control to allow for one float to fail without compromising operation.
- Less components for failure and better components to guarantee over 1,000,000 cycles.
- Wi-Fi enabled allowing for remote monitoring via SideWinder Tech.
- The control panel has all the classic capabilities including the manual running of pumps (hand), automatic swapping of pumps and ability to set pumps offline.
- Offering a volt free contact, the Rego1 allows connection of external devices such as an alarm or beacon with a maximum load of 0.5A and voltage up to 30V.
- The VFR can also be connected to any BMS system if required for high level alarm only, sending a continuous signal.



TECHNICAL SPECS

Size (without cable glands)	310mm x H: 170mm x D: 78mm
Weight	1kg (including battery)
Mains Supply	200-250V AC (50Hz)
Internal Battery	Pb 6V - 1.2Ah
Alarm Sound Level	100db @ 30cm
Operating Temperature	5-40°C
Power Consumption (Idle)	<2W
IP	IP2X
Electrical Requirements	1 Spur
Visual Display	2 Displays: 2 x 7 Segments

WARRANTY

Rego1 is offered with a 24 month component warranty. This warranty only covers any defects in workmanship, construction or material. This warranty does not cover, defects caused by incorrect installation, installer error, abnormal working conditions, misuse or neglect.

HEALTH & SAFETY

In order to minimise the risk of ill health or accidents when installing and/or servicing pump chambers and associated accessories, workers must be fully trained and competent.

The following guidelines will help safeguard matters:

- Assessing the risk and working in accordance with the control measures identified.
- Ensure electrical power to the equipment is isolated before carrying out installation or maintenance.
- A suitable first aid kit must be close to hand.
- The electrical installation must comply with the requirements of BS 7671:2018 'Requirements for Electrical Installations' incorporating the latest amendments.

CONNECTIVITY

The Rego1 can be a stand alone control panel or it can be connected to the SideWinder Tech remote monitoring software via Wi-Fi. This enables various 'smart' functionality, remote monitoring capabilities to allow for predictive maintenance and the ability to remotely control the Rego1 from anywhere in the world!

The Rego1 can be used in conjunction with the PowerMaxx2 range of products to provide battery back up in the event of a mains power failure



REGO1

TECHNICAL DRAWINGS

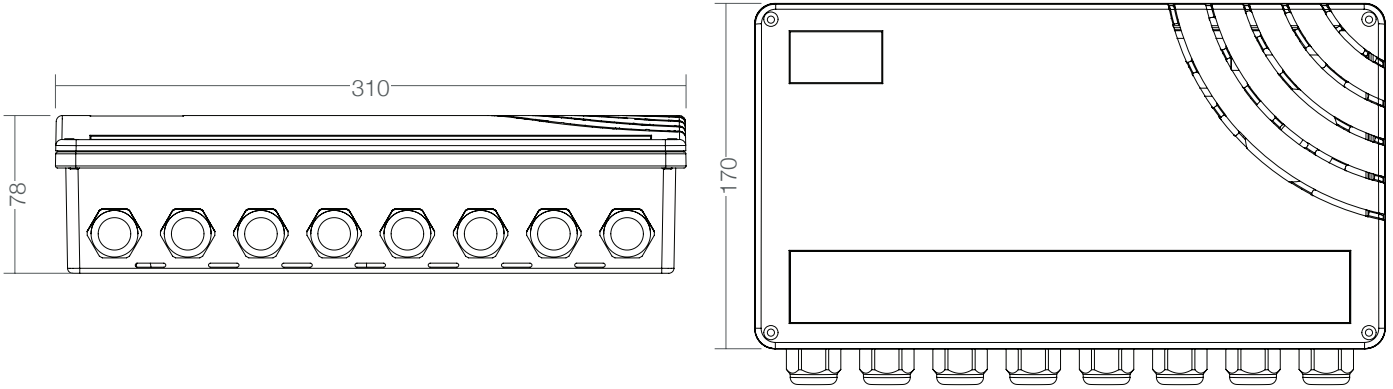

WIRING DIAGRAM – DUTY / STANDBY DUAL FOUL

