

DUAL GROUND WATER PUMP STATION WITH ALERTMAXX2 AND POWERMAXX2

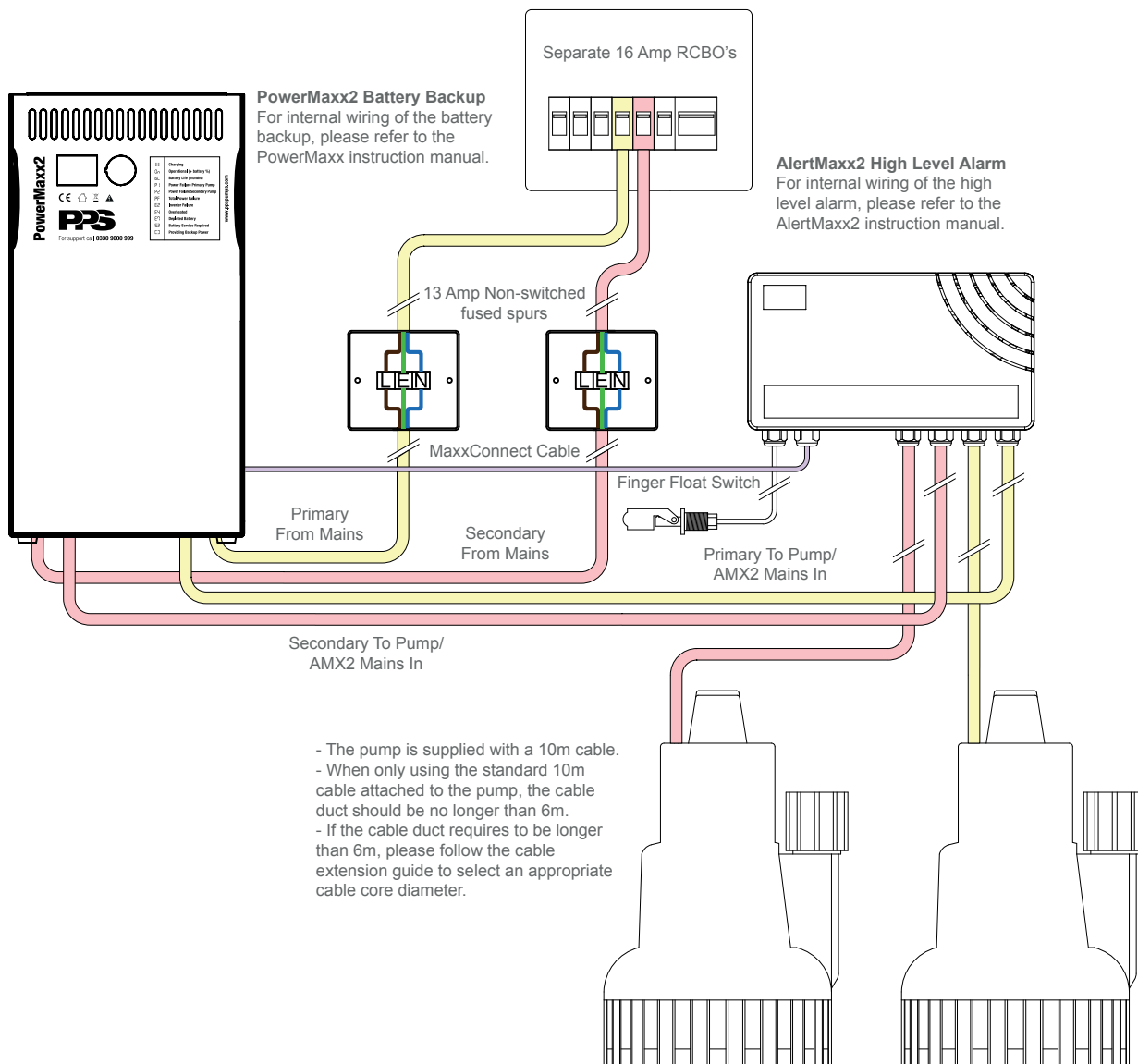

The electrical installation must comply with the requirements of BS 7671:2018 'Requirements for Electrical Installations' incorporating the latest amendment.